



**AIR PRODUCTS AND CONTROLS INC.**  
**INSTALLATION AND MAINTENANCE INSTRUCTIONS**  
**FOR SL-2000 SERIES DUCT SMOKE DETECTORS**

**SL-2000-N** 4-Wire, Ionization Type  
**SL-2000-P** 4-Wire, Photoelectric Type

**PRODUCT OVERVIEW**

**PRODUCT APPLICATION**

SL-2000 Series duct smoke detectors provide early detection of smoke and products of combustion present in air moving through an HVAC duct supply, return, or both in commercial, industrial, and residential applications. These devices are designed to prevent the recirculation of smoke in areas by the air handling system's fans and blowers. Complete systems may be shut down in the event of smoke detection.

**NOTE:** For the correct installation of a duct smoke unit, please refer to the NFPA 72 (National Fire Alarm Code), NFPA 90A (Standard for Installation of Air Conditioning and Ventilation Systems), NFPA 92A (Recommended Practice for Smoke Control Systems.), NFPA 5000 (Building Construction and Safety Code), IMC (International Mechanical Code), and IFC (International Fire Code).

This detector is not intended for open area protection nor should it be used for early warning detection or replace a regular fire detection system.

**PRODUCT DESCRIPTION**

The SL-2000 Series smoke detector is fitted with a mounting base that will accept an ionization smoke detector head model 55000-225APO or photoelectric smoke detector head model 55000-328APO. The duct unit supports two sets of form "C" alarm contacts, one form "A" alarm contact and one form "C" trouble contact. The trouble contact supervises the presence of the input power, removal of the detector cover and the removal of the smoke detector head.

**⚠ This detector is equipped with a cover removal switch that instantly provides a trouble condition upon removal of the clear cover. For all testing and inspection with the cover removed, the cover removal switch (designated as SW1 on PCB) must be manually depressed to simulate standard "pilot" operation. THE TROUBLE CONTACTS (TERMINALS 4, 15, 5) ARE SHOWN IN THE NON-ENERGIZED CONDITION.**

The trouble contacts **will not** operate in the event of a smoke alarm. The SL-2000 Series duct detector will operate from various input voltage sources; namely 24VAC, 24VDC, 115VAC and 230VAC.

**SAMPLING TUBES**

The operating principle of a duct detector is based on the Venturi effect. Two tubes extend into the HVAC duct. Air flowing through the duct is forced into the air intake (inlet) tube via the air intake holes, (facing the airflow) and passes over the detector head. The air will be drawn out via the exhaust tube back into the HVAC duct. (A 7" exhaust tube is provided in the installation kit.) When the concentration of smoke particles suspended in the air stream reach the alarm threshold of the detector head, the unit will go into alarm.

The duct smoke detector units are designed to operate in duct widths from 6" to 10' wide with an air velocity between 100 to 4,000 feet per minute. To verify correct installation, the pressure differential between the sampling (high side) and exhaust (low side) tubes should be measured using a Magnehelic pressure gauge or equivalent. An acceptable reading is between 0.01 and 1.2 inches of water.

To minimize the impact of air turbulence and stratification on performance, a duct smoke detector should be located as far as possible downstream from any obstruction (i.e. deflector plates, elbows, dampers, etc.). In all situations, confirmation of velocity and pressure differential within specifications is required.

**REMOTE ACCESSORIES**

Audible and visual alarm indicators, remote status indicators, and remote reset/test switches can be accommodated by the SL-2000 Series duct units by connecting to DC voltage output terminals as described on Page 4. These terminals are not supervised and the voltage/current will only be present when the detector unit is in alarm. The remote pilot (green) LED will be permanently illuminated when connected to the output terminals as long as input power and detector head are present.

**SL-2000 AT-A-GLANCE**

**MODEL NUMBER:**

SL-2000-N 4-Wire Ionization Duct Smoke Detector  
SL-2000-P 4-Wire Photoelectric Duct Smoke Detector

**DETECTOR HEAD MODEL NUMBER:**

Ionization Detector Head: **55000-225APO**  
Photoelectric Detector Head: **55000-328APO**

POWER	STANDBY CURRENT		ALARM CURRENT	
		WITH ACCESSORIES		WITH ACCESSORIES
24VAC	55.0mA	95.0mA	190.0mA	280.0mA
24VDC	14.0mA	32.0mA	68.0mA	165.0mA
115VAC	22.0mA	25.0mA	32.0mA	50mA
230VAC	14.0mA	14.0mA	18.0mA	30.0mA

**RELAY CONTACT RATINGS:**

Alarm contacts: 2 Sets form "C" rated at 10A @ 115VAC resistive  
1 form "A" rated at 2A  
Trouble contacts: 1 Set form "C" rated at 10A @ 115VAC resistive  
Air velocity: 100 to 4,000ft/min.  
Ambient temperature: SL-2000-N: 32°F to 158°F (0°C to 70°C)  
SL-2000-P: 32°F to 140°F (0°C to 60°C)  
Humidity: 10% to 85% RH Non-Condensing/Non-Freezing  
Material: Gray plastic back box with clear plastic cover (Makrolon 94V-0)  
Dimensions: 13½" L X 4½" W X 2¼" D  
Max. net wt.: 3½ lbs.  
Radioactive element: SL-2000-N (Ionization) - Americium 241, 0.9 micro curie.

**Do not expose to corrosive atmospheres.**  
U.S. Patents 6,741,181; 7,204,522; 6,124,795

# MECHANICAL INSTALLATION

## LOCATION PREREQUISITES

This guideline contains general information on duct smoke detector installation, but does not preclude the NFPA and/or ICC documents listed. Air Products and Controls assumes no responsibility for improperly installed duct detectors. To determine the correct installation position for an SL-2000 Series duct smoke detector, the following factors must be considered.

1. A uniform non-turbulent (laminar) airflow between 100 ft/min. to 4,000 ft/min. must be present in the HVAC duct. To determine duct velocities, examine the engineering specifications that define the expected velocities or use an Anlor model 6000AP velocity meter (or equivalent).
2. To minimize the impact of air turbulence and stratification on performance, a duct smoke detector should be located as far as possible downstream from any obstruction (i.e. deflector plates, elbows, dampers, etc.). In all situations, confirmation of velocity and pressure differential within specifications is required.

The pressure differential between the input sampling (high pressure) tube and exhaust (low pressure) tube for the SL-2000 Series smoke duct detector should be greater than 0.01 inches of water and less than 1.2 inches of water.

3. Identify a code compliant location (supply or return side, or both) for the installation of the duct unit that will permit easy access for viewing and serviceability.
4. When installing on the return side, install duct units prior to the air being exhausted from the building or diluted with outside "fresh" air.
5. When installing duct smoke units downstream of filters, fires occurring in the filters will be detected, but if the filters become blocked, insufficient air flow through the duct unit will prevent the correct operation of the duct detector. Duct units installed in the supply air side may monitor upstream equipment and/or filters.
6. Where possible, install duct detectors upstream of air humidifiers and downstream of dehumidifiers.
7. To prevent false alarms, the duct detector should not be mounted in areas of extreme high or low temperatures, in areas where high humidity exists, or in areas where the duct may contain gases or excessive dust.

## SAMPLING TUBE ASSEMBLY

The SL-2000 Series duct smoke detectors employ a specially notched sampling tube, which must be ordered separately in one of four standard lengths or packaged as FAST Tubes.

- STN-1.0 For duct widths of 6" TO 1.0'
- STN-2.5 For duct widths of 1.0' TO 3.0'
- STN-5.0 For duct widths of 3.0' TO 5.0'
- STN-10.0 For duct widths of 5.0' TO 10.0'
- FAST TUBE Sectional tube for duct widths up to 8.0'

Standard sampling tubes are steel tubes with air intake holes drilled the entire length of the tube. FAST Tubes are a recognized plastic with an open slot along the length. These tubes can be cut to length and must span at least 80% of the duct width (spanning the entire width is suggested). Sampling tubes over 3ft must be supported on the opposite side of the duct. To ensure correct operation of the sampling tube, the red end cap (red stopper in installation kit) must be inserted in the end of the air intake. For custom duct widths, always use the next longest standard size and cut down to the exact requirement.

## "NO-TOOLS" TUBE INSTALLATION

The SL-2000 Series duct smoke detector provides a unique, patented mechanism for installation and/or removal of the sampling and exhaust tubes from either the front or rear of the detector housing.

Once the airflow direction has been determined, insert the inlet and exhaust tubes into the duct smoke detector. If the cover is in place, the tubes may be inserted into the back of the detector via the key-slots provided. Simply push the tube into place against the spring loaded retainer, and turn into the correct position, allowing the key to "lock" the tube in the desired orientation. For front side installation, simply rotate the tube retainer until the tube may be inserted and oriented properly. Once the tube is installed, rotate the retainer back into place to lock down the tube. Ensure air intake sampling tube is positioned so that the inlet holes (or FAST Tube slot) are directly facing the airflow.

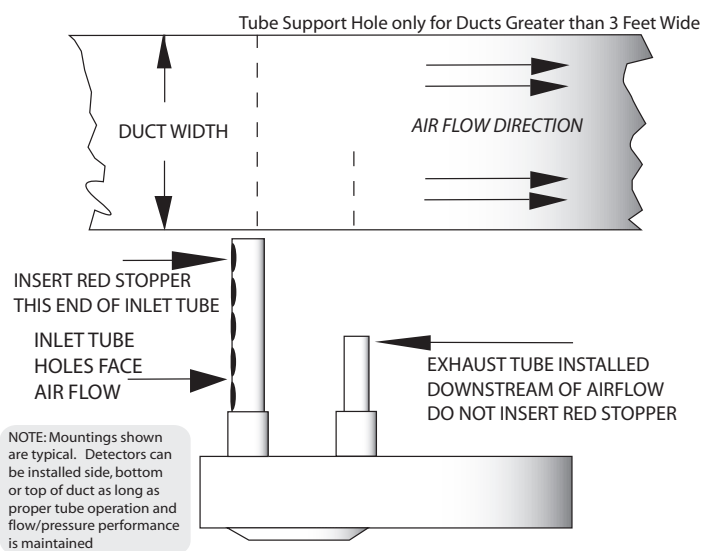

## DUCT PREPARATION

Remove mounting template from the installation kit. Remove paper backing from the mounting template and affix it to the duct at the desired location. Using the template as a guide, drill (2) mounting holes, 3/32" (2.5mm) for the #12 X " sheet metal screws packaged in the installation kit. Drill or punch (2) 1" (32mm) holes for inlet sampling and exhaust tubes, using the template as a guide. Clean all holes.

## MOUNTING

After securing the sampling and exhaust tubes to the duct smoke unit, (or initially placing the tubes through the 1" holes drilled or punched in the HVAC duct to accept the inlet sampling and exhaust tubes and then attaching them to the duct unit), hold the duct unit assembly in position and use (2) # 12 X " sheet metal screws (packaged in the installation kit) to secure the duct smoke detector to the HVAC duct sheet metal.

## AIR SAMPLING VERIFICATION

To ensure correct operation of the duct unit use a Magnehelic differential pressure gauge, Dwyer 2000 or 4000 Series (or equivalent) to determine the differential pressure between the inlet (high side) and exhaust (low side) tubes. The differential pressure between the two tubes should be greater than 0.01 inches of water and less than 1.2 inches of water.

**AIR SAMPLING VERIFICATION (CONT'D)**

This duct smoke detector is shipped with a velocity adapter insert, either factory installed (SL-2000-P), or found in the installation kit (SL-2000-N). When installed, this adapter will allow the duct detector to operate at extremely low air velocities. To install the adapter, simply insert it into the slots provided inside the detector housing so that the adapter fits snugly over the smoke detector head. Unless your system is consistently operating in the slower velocity range (where the adapter is specifically required, SL-2000-N), we recommend that the adapter not be inserted. If you experience false alarms at higher velocities with the adapter in place, the adapter should be removed. Please use the following chart for guidance on when the velocity adapter should be used. For reference, the speeds indicated are intended to represent the velocity of air within the duct under normal operational conditions.

	100 ft/min	300 ft/min	500 ft/min	1,000 ft/min	2,000 ft/min	3,000 ft/min	4,000 ft/min
<b>SL-2000-N</b>	UL Listed <b>without</b> insert installed (300-4,000 ft/min)						
	UL Listed <b>with</b> insert installed (100-2,000 ft/min)						
<b>SL-2000-P</b>	UL Listed <b>without</b> insert installed (1,000-4,000 ft/min)						
	UL Listed <b>with</b> insert installed (100-4,000 ft/min)						

## ELECTRICAL INSTALLATION

### TERMINAL AND POWER CONNECTIONS

Prior to connecting input power to the duct unit, determine the correct input voltage/ current availability and ensure it is connected to the correct terminals.

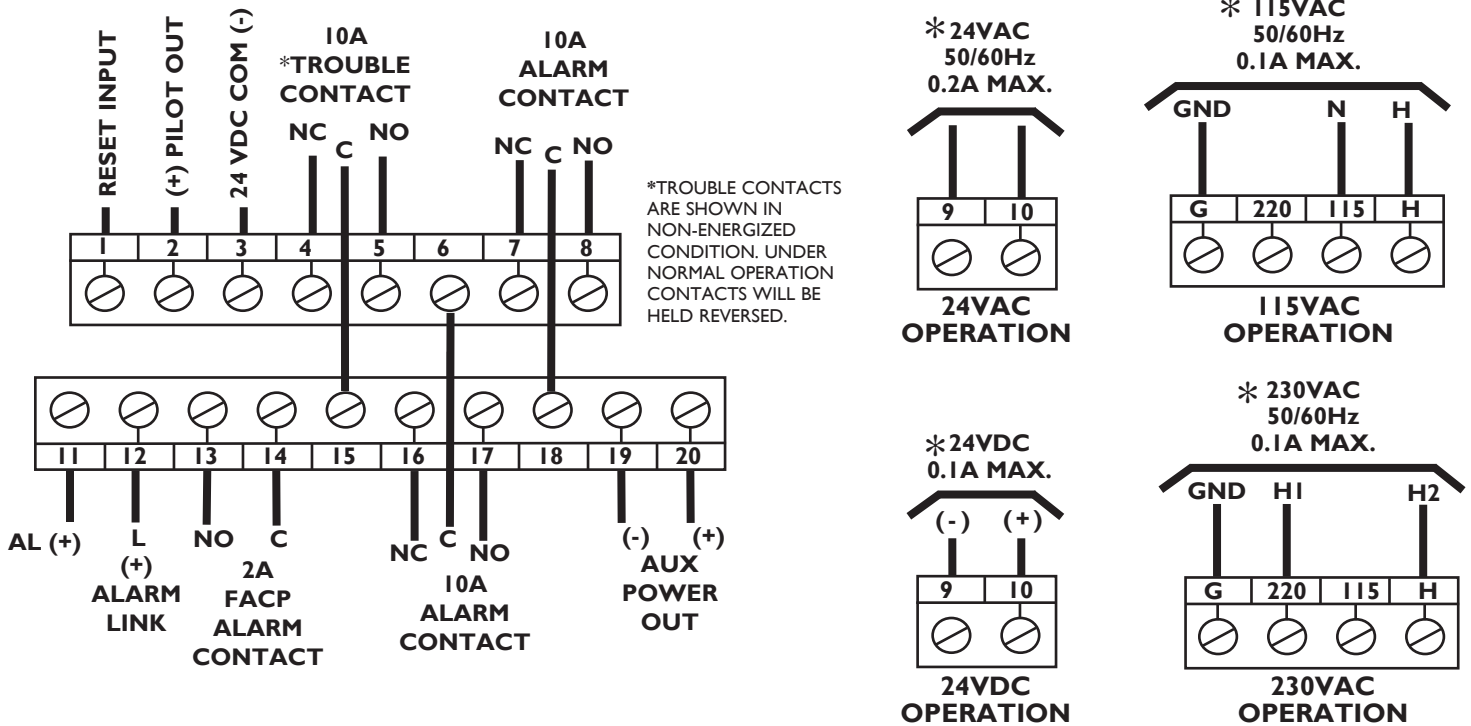

\* NOTE: Choose only one source of operating voltage

### WIRING

**CAUTION:** Do not use looped wire under terminals. Break wire run to provide for proper supervision of connections.  
**MISE EN GARDE:** Ne pas enrouler le fil sous les bornes. Pour assurer la supervision électrique des raccordements, il faut couper les fils.

With detector head removed, connect one of the appropriate dedicated power sources to the applicable terminals (see above). Replace detector head and depress the cover removal switch (SW1) and the unit will be energized. The green pilot LED will be illuminated, and when pressing the test/reset button (SW2), the red alarm LED will be illuminated. This test confirms the correct basic operation of the duct smoke unit, excluding the detector head (see functional testing).

In the event of a fire alarm, certain equipment may be required to be shut down. For example, shut down may be achieved by interrupting the fan supply source to that particular piece of equipment when wired as indicated on Page 4.

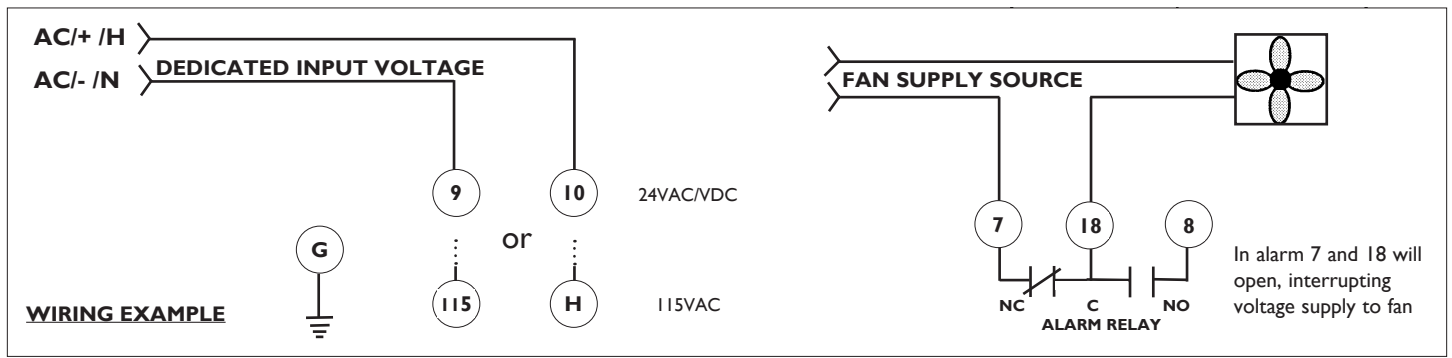

## FIRE ALARM CONTROL PANEL WIRING

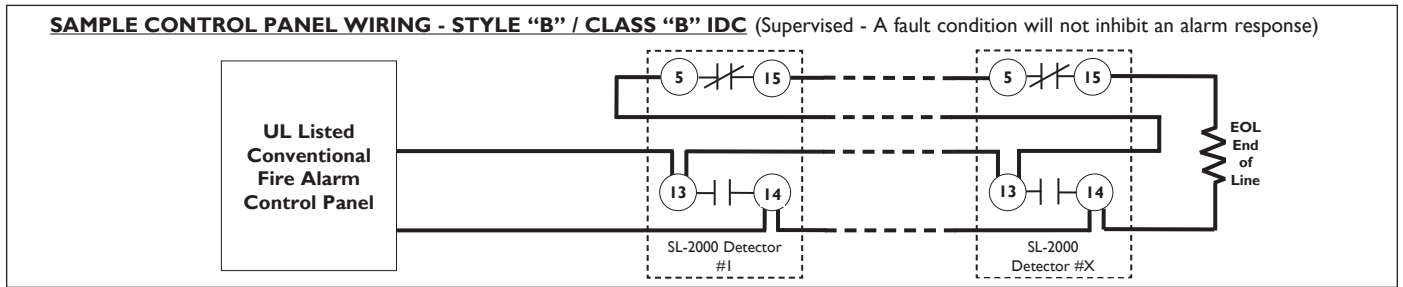
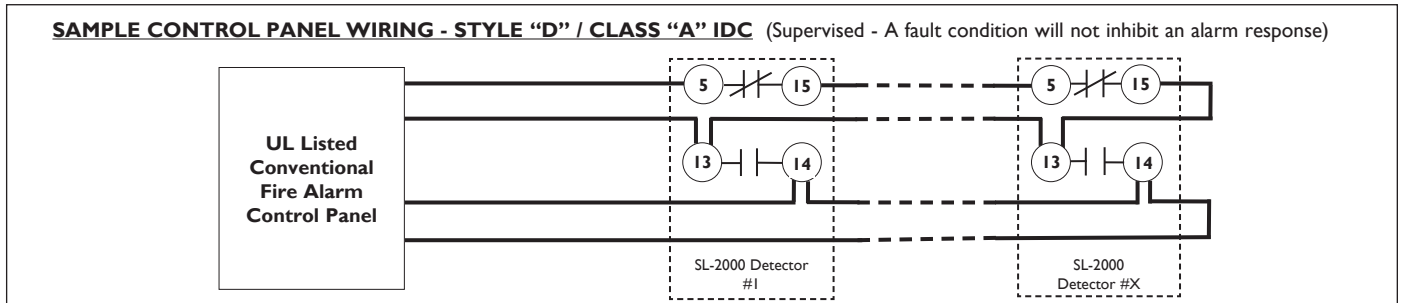

## MSR REMOTE ACCESSORY WIRING

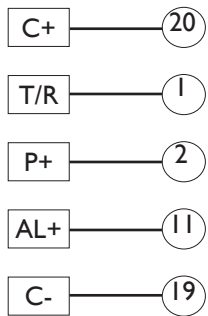

**CONNECTIONS SHOWN FOR ALL POSSIBLE TERMINAL STYLE CONFIGURATIONS.**

**CONNECT ONLY THOSE TERMINALS AVAILABLE ON THE MSR REMOTE ACCESSORY CONTROL ASSEMBLY.**

## MS REMOTE ACCESSORY WIRING

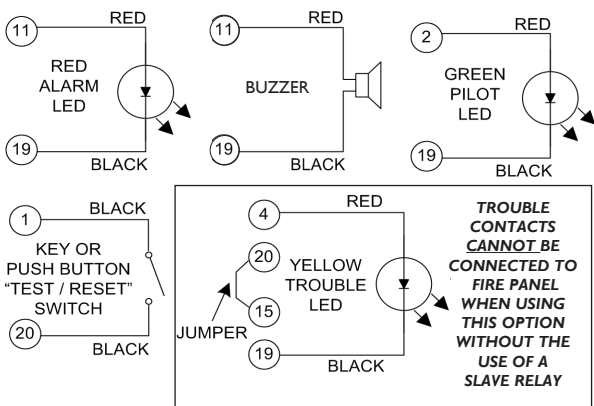

## INTERCONNECTION WIRING FOR COMMON FUNCTIONS

**\* NOTE:** A common power supply must be used for all interconnected detectors.

### Common Test/Reset

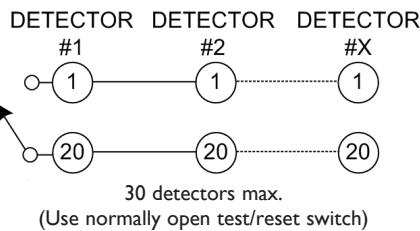

### Common Alarm Shutdown

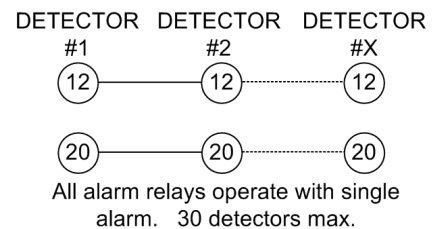

### Adding Individual Horn/Strobes

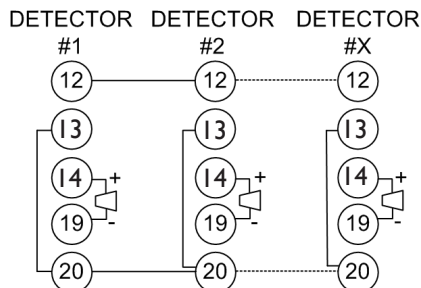

All alarm relays operate with single alarm. Individual horn/strobe units operate on alarmed detector only. 30 detectors max.

### Adding Common Alarm Horn/Strobes

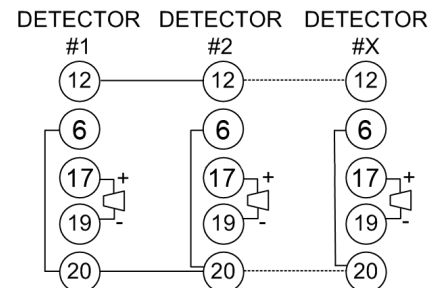

All alarm relays operate with single alarm. All horn/strobe units operate on any single alarm. 30 detectors max.

# TESTING AND MAINTENANCE PROCEDURES

## OPERATIONAL TESTING

To determine the correct operation of the SL-2000 Series duct smoke detector, ensure input power is connected and the green pilot LED is illuminated.

The LED on the detector head of both the ionization and photoelectric models will flash while the unit is in standby mode. The LED on the smoke detector head will be permanently illuminated when smoke is detected and the head is in alarm.

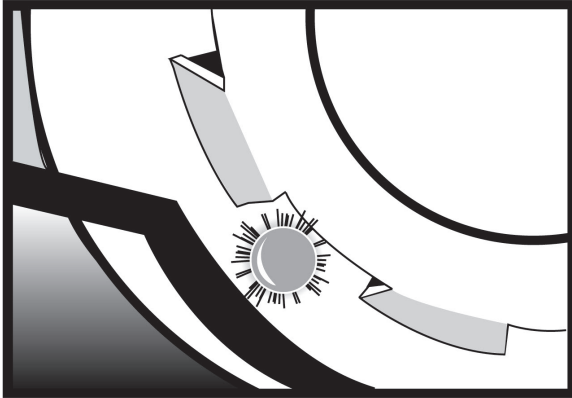

Above: The LED will be permanently illuminated when the unit is in alarm.

With the air handling unit shut down (not connected), and the clear cover removed, press and hold the test/reset button and the cover removal switch on the SL-2000. The red alarm LED on the circuit board will be illuminated and the alarm relay outputs will change state. Using a multimeter set to OHMS (or continuity buzzer function on the meter) place the meter probes on the following terminals, and ensure the contacts are closed (continuity) (8-18) and (6-17). When releasing the test/reset button these contacts will open.

The trouble contacts (4,15,5) on the SL-2000 detector will not change state in the event of a fire alarm, operational, or functional testing. The trouble contacts can be tested by either releasing the cover removal switch, or depressing the cover removal switch after rotating the smoke detector head counter-clockwise and removing the detector head. This action will extinguish the green pilot LED and cause the trouble contacts to change state, (4-15) will be closed (continuity) and (5-15) will be open circuit. Replacing the detector head and rotating it clockwise until it locks, will cause the green pilot LED to be illuminated and the unit will be operational, terminals (4-15) will be an open circuit and (5-15) will be closed (continuity).

## FUNCTIONAL TESTING

Once operational testing is concluded the unit requires functional testing to determine the correct operation of the detector head.

**MAGNET TESTING:** Place the magnet provided with the installation kit on top of the housing between the raised sections above the detector head (as indicated by the arrows on the unit cover). Allow at least five seconds for alarm initiation. Remove magnet and reset detector.

**SMOKE TESTING:** Using smoke test canister with testing nozzle (available from Air Products and Controls Inc. part number TG-2000), insert the test gas nozzle into the test port on the unit cover. Press can against cover to release gas into the chamber.

**CAUTION:** DO NOT SPRAY GAS FOR MORE THAN ½ SECOND. TEST GAS FACILITY MAY RESULT IN DETECTOR CONTAMINATION.

**MISE EN GARDE:** NE VAPORISEZ PAS DE GAZ POUR PLUS DE ½ SECONDE. SURUTILISATION DES GAZ DE TEST INSTALLATION PEUT ENTRAÎNER LA CONTAMINATION DU DÉTECTEUR.

After 15 to 20 seconds the detector head will go into alarm, illuminating the detector head LED and causing the duct unit functions to operate, alarm relays will change state, and the alarm related remote accessories, if attached, will function.

If no test gas is available to conduct functional testing, remove cover and, while holding down the cover removal switch, blow smoke from a cotton wick or punk directly at the head to cause an alarm. The alarm indicator should illuminate within one minute.

Should additional testing also be required for simulated fire conditions, smoke bombs placed in the duct may not be suited for the particular detector head (photoelectric or ionization) selected and installed. Consult the smoke bomb data for proper use and compatibility with detector type.

The S65A ionization detector head (55000-225APO) utilizes a radioactive source as its means of detection and will detect smoke particles of between .1 and 1 micron in size.

The S65A photoelectric detector head (55000-328APO) operates on the principle of light scatter and will detect smoke particles of between 1 and 10 microns in size.

When purchasing smoke bombs for additional required functional testing, ensure smoke particle sizes comply with the criteria as described above.

**NOTE:** In situations that require a duct smoke detector to be held in an alarm condition for an extended period of time, the magnet test or smoke test methods should be used to ensure the detector is locked into alarm.

## MAINTENANCE

Each installation location must be assessed on its own merits. If the protected area is of a very dirty nature then the SL-2000 Duct unit(s) will have to be checked and cleaned on a quarterly basis or when cleaning is required.

As a guideline the smoke detector head should be cleaned every six months or as required. The best methods of cleaning are to vacuum the detector head thoroughly or to blow the detector head out using clean, dry compressed air.

Do not use chemicals or non-conforming air to clean the detector head housing as this could contaminate the detector head and damage the casing.

Sensing tubes must be inspected and cleaned in accordance with the schedule as determined above, to allow the free flow of air through both inlet and exhaust tubes.

Consult your local code and AHJ requirements for required maintenance schedules.



AIR PRODUCTS AND CONTROLS INC.  
25 Corporate Dr. Auburn Hills, MI 48326 USA  
Telephone: (248) 332-3900 www.ap-c.com

## AVAILABLE ACCESSORIES FOR USE WITH SL-2000 SERIES DUCT SMOKE DETECTORS

### MSR- SERIES REMOTE ACCESSORIES

**MSR-100R Series Features Visual Indicators:** Alarm, Pilot, Trouble • Buzzer: Programmable for Alarm and Trouble Buzzer Silence: Visual Notification and Ringback • Detector Test/Reset: Key Operated • LED/Buzzer Test: Push-Button Operated

**MSR-50RM Series Features Magnet Test, Pushbutton Reset, Visual Pilot, Trouble, Alarm LED**

**MSR-50RK Series Feature Key Test & Reset with Visual Pilot, Trouble, Alarm LED**

**MSR-AV Series Features plug-in combination Strobe (Visual) and Sounder (AMSR-50SA Series Features plug-in combination Strobe (Visual) and Sounder (Audible)**

### MS-SERIES REMOTE ACCESSORIES

MS-RA Remote Alarm

MS-RA/R Alarm, push button Test/Reset Switch

MS-RA/P/R Remote Alarm, Pilot, push-button Test/Reset Switch

MS-KA/R Remote Alarm, key-operated Test/Switch

MS-KA/P/R Remote Alarm, Pilot, key-operated Test/Reset Switch

MS-RA/P Remote Alarm, Pilot

MS-RH Remote Alarm Horn

MS-RH/KA/P/R Remote Alarm, Pilot, Horn, key-operated Test/Reset Switch

MS-RH/P/A Remote Alarm, Pilot, Horn

MS-RH/KA/P/A/T Remote Alarm, Trouble, Pilot, Horn, key-operated Test/Reset Switch

MS-RA/P/T Remote Pilot, Trouble

MS-RA/FT/P Remote Pilot, Trouble, push-button Test/Reset Switch

MS-KA/P/R/T Remote Pilot, Trouble, key-operated Test/Reset Switch

MS-RD Remote Alarm

MS-F/T Remote Trouble

### SMOKE TEST GAS

TG-2000 Solo Aerosol Test Gas with Nozzle for Test Port

### SAMPLING TUBES

STN-1.0 For duct widths of 6" to 1.0'

STN-2.5 For duct widths of 1.0' to 3.0'

STN-5.0 For duct widths of 3.0' to 5.0'

STN-10.0 For duct widths of 5.0' to 10.0'

FAST Tube Sectional Tube for Duct Widths up to 8ft

### REPLACEMENT SMOKE DETECTOR HEADS

55000-225APO S65A Ionization Detector Replacement Head

55000-328APO S65A Photoelectric Detector Replacement Head

### POWER SUPPLIES

T-PB 202-1 24VAC @ 4.0A Class I Power Supply

T-PB 202-0 24VAC @ 4.0A Class I Power Supply

T-PB 303-1 24VAC @ 3.0A Class II Power Supply

T-PB 303-0 24VAC @ 3.0A Class II Power Supply



## SL-2000 SERIES DUCT SMOKE DETECTORS

## INSTALLATION AND MAINTENANCE INSTRUCTIONS



**SL-2000-N** Ionization Type, 4-Wire Duct Smoke Detector

**SL-2000-P** Photoelectric Type, 4-Wire Duct Smoke Detector



ANSI APPROVED / UL LISTED to the 268A Standard  
for Smoke Detectors for Duct Application:  
UROX, UROX7, File No S2829

CSFM LISTED: 3240-1004:105 • MEA ACCEPTED: 73-92-E VOL 27

**NOTICE:** The information contained in this document is the most current available at the time of shipment of accompanying product, and is subject to change without notice. Future references should always be made to the most current revision of this document. The information contained in all this document should be considered before installing or using the product. Any example applications shown are subject to the most current enforced local/national codes, standards, approvals, certifications, and/or the authority having jurisdiction. All of these resources, as well as the specific manufacturer of any shown or mentioned related equipment, should be consulted prior to any implementation. For further information or assistance concerning this product, contact Air Products and Controls Inc. Air Products and Controls Inc. reserves the right to change any and all documentation without notice.  
© Air Products and Controls Inc. 2009

**A COPY OF THESE INSTRUCTIONS SHOULD BE LEFT WITH THE EQUIPMENT  
UNTIL INSTALLATION BY ALL TRADES IS FULLY COMPLETE.  
FOLLOWING FINAL INSPECTION, A COPY SHOULD BE LEFT WITH THE OWNER/USER.**

FOR TECHNICAL SUPPORT CALL 888-332-2241 OR 248-332-3900